



Portable
Telescoping
Pneumatic
Hoist

SUPER HOIST™

- Lightweight, portable material lift powered by CO₂ or compressed air.



Standard Features

- **The Super Hoist sets up in seconds.** No special tools are required. The legs fold out from the base for quick and easy setup.
- **The one-piece platform** attaches to the cylinder with a twist of the wrist. When not in use, the hose stores easily around brackets underneath the platform.
- **Captive legs** complete the streamlined design of the patented base assembly. Easy-to-release safety lock mechanisms keep each leg “up” for storage or “out” for use. Casters lock in place with a touch from your toe.

▪ **Easy to operate.** Up and down functions, including the dump valve, can all be activated from the patented control handle. When not in use, the pistol-grip handle conveniently clips to a storage button on the side of the cylinder.

- The Super Hoist is **powered by either CO₂ or compressed air.**
- **Any bottle will do.** The “one size fits all” CO₂ bottle mounting bracket accepts any common bottle size.
- **Completely portable.** The compact size and weight of the Genie Super Hoist makes it possible for one person to move it quickly and effortlessly from job to job.
- **Auto-lubricating.** There is an oil reservoir on top of each piston inside the cylinder. This patented design ensures proper lubrication and helps prevent the lubricating oil from draining.
- Every part on the Genie Super Hoist is **completely serviceable.** Now, if you need to replace a seal, the job can be completed in minutes.
- **Built to last,** the Genie Super Hoist is constructed from heat-treated, extruded aluminum.

Accessories

- 20 lb (9 kg) CO₂ tank
- Platform cradle package

The Genie Super Hoist lifts, positions and installs:

- Metal and fiberboard air ducts
- Overhead sprinklers/plumbing
- Sheetrock and ceiling panels
- Forced air heaters/chillers
- Chimney pipe
- Electrical fixtures

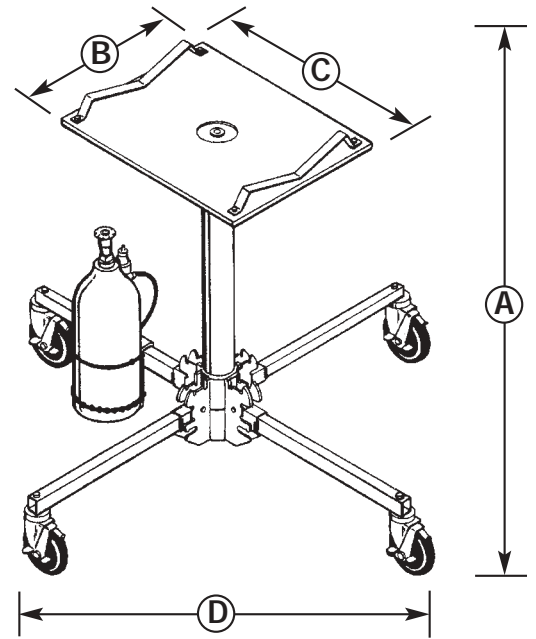

Specifications

Model	GH 3.8	
	US	Metric
Ⓐ Height - stowed	41 in	1.04 m
Ⓑ Platform length	19 in	48 cm
Ⓒ Platform width	24 in	61 cm
Ⓓ Base width		
corner-to-corner	53 in	1.35 m
Load capacity	300 lb	136 kg
Lifting height	12 ft 5 5/8 in	3.8 m
Dimensions for		
storage/transport	14 x 14 x 39 1/2 in	36 cm x 36 cm x 1 m
Weight	64 lb	29 kg
Recommended psi	85 psi	5.86 bar
Model	GH 5.6	
	US	Metric
Ⓐ Height - stowed	54 in	1.37 m
Ⓑ Platform length	19 in	48 cm
Ⓒ Platform width	24 in	61 cm
Ⓓ Base width		
corner-to-corner	53 in	1.35 m
Load capacity	250 lb	113 kg
Lifting height	18 ft 4 1/2 in	5.6 m
Dimensions for		
storage/transport	14 x 14 x 39 1/2 in	36 cm x 36 cm x 1 m
Weight	69 lb	31 kg
Recommended psi	85 psi	5.86 bar

Distributed By:

Genie Industries

GENIE UNITED STATES

18340 NE 76th Street
P.O. Box 97030
Redmond, Washington 98073-9730
Telephone (425) 881-1800
Toll Free in USA/Canada 800-536-1800
Fax (425) 883-3475
http://www.genieindustries.com

GENIE UNITED KINGDOM

The Maltings, Wharf Road
Grantham
Lincolnshire NG31 6BH
England
Telephone: +44 (0)1476 584333
Fax: +44 (0)1476 584334
http://www.genieindustries.com